

2331XP-SA

COMMONLY SERVICED COMPONENTS

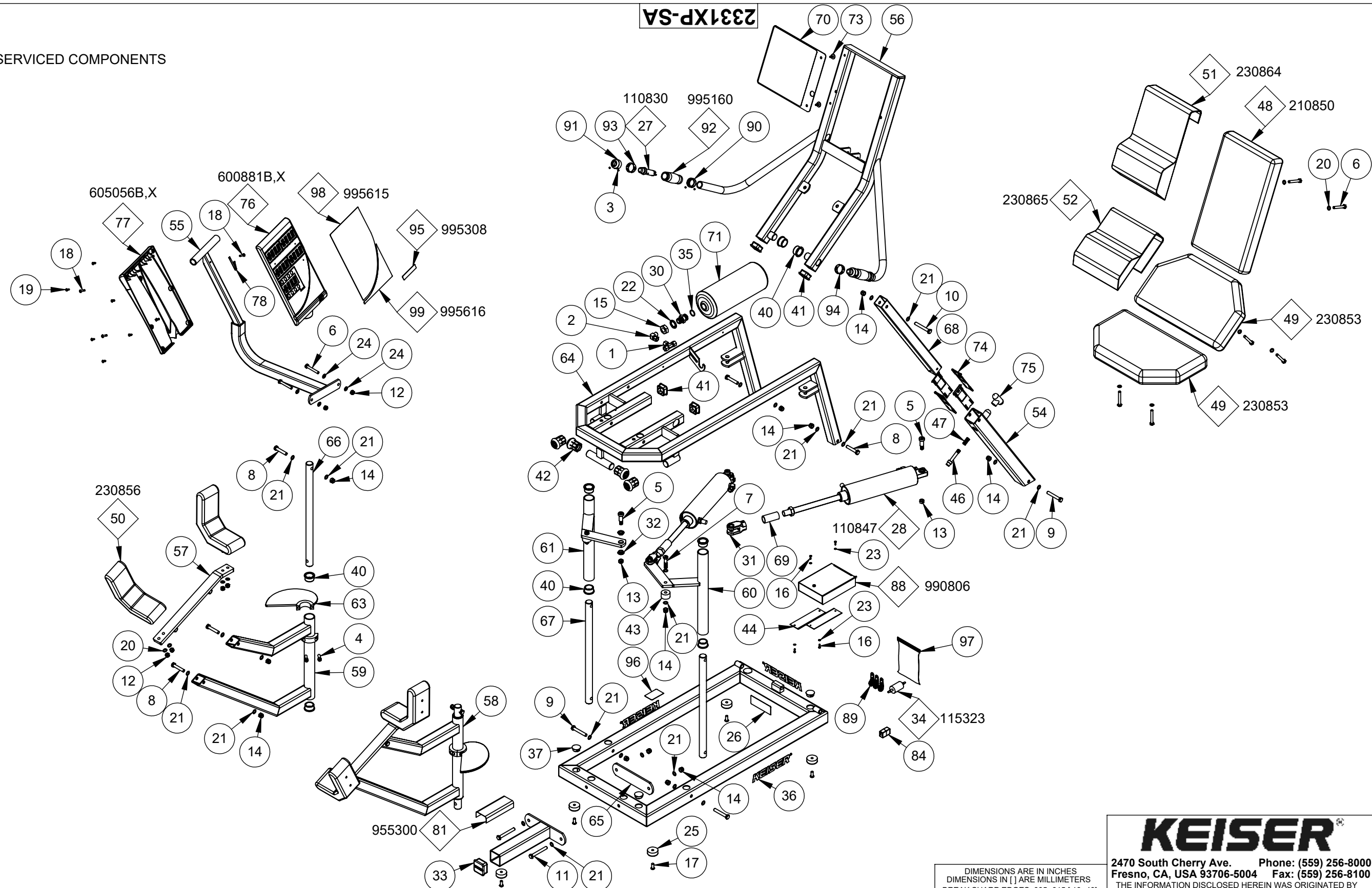

NOTE:
(1) THIS DRAWING COVERS: 2331BP, 2331PP AND 2331SP
(2) FOLLOW ALL TOP LEVEL PROCEDURES

REV	ECO	REVISION DESCRIPTION	BY	CKD	DATE
A	3928	REFERENCE ECO MEMO FOR DETAILS	JPR	LC	9/10/21

DIMENSIONS ARE IN INCHES
 DIMENSIONS IN [] ARE MILLIMETERS
 BREAK SHARP EDGES .005-.015 [.10-.40]
 MACHINED SURFACE FINISH IS
 63 MICRINCHES [1.6 MICROMETERS]
 DO NOT SCALE DRAWING

DRAWN BY: JPR DATE DRAWN: 7/19/21 CHECKED BY: LC DATE CHECKED: 9/10/21

MATERIAL:
 RAW MAT: MASS (Kg):

TITLE: **A300 HIP ABDUCTOR - PWR-SA**
 SHEET 1 OF 2 SCALE: 1:12 DRAWING SIZE: A PART#: 2331XP-SA

KEISER
 2470 South Cherry Ave. Phone: (559) 256-8000
 Fresno, CA, USA 93706-5004 Fax: (559) 256-8100
THE INFORMATION DISCLOSED HEREIN WAS ORIGINATED BY AND IS THE PROPERTY OF KEISER CORP. AND ALL PATENT, PROPRIETARY, DESIGN, USE, SALE, MANUFACTURING, AND REPRODUCTION RIGHTS THERETO ARE RESERVED BY KEISER CORP.

PRINTED ON: 9/10/2021 SW2006 V5.1

X:\drawings\REVISION\23_HIP_ABDUCTOR\

ITEM NO.	QTY.	PART NO.	TITLE	ITEM NO.	QTY.	PART NO.	TITLE
1	1	8101	TEE - UNION-3/8	64	1	230918	CTR FRM
2	1	8153	CAF - ME-3/8 C X 1/4 M	65	1	231859	PLATE - BASE EXTENSION
3	8	9014	SCREW - HSSS 8-32 X 1/8 SS	66	2	232243	PIVOT SHAFT - ARM PIVOT
4	4	9105	SCREW - SHCS 5/16-24 X 7/8	67	2	232245	SHAFT - CONTROL BOX
5	4	9127	SCREW - SHSS 1/2 X 1 ZP	68	1	234163	TUBE - SEAT
6	8	9179	SCREW - HHCS 5/16-18 X 2-1/4 ZP	69	2	235050	CYLINDER - STOP
7	2	9204	SCREW - HHCS 0375-16 X 1750 ZP	70	1	235447	PLACARD - A300 HIP ABDUCTOR
8	8	9205	SCREW - HHCS 3/8-16 X 2 ZP	71	1	255318	TANK - 140 CU IN
9	3	9207	SCREW - HHCS 3/8-16 X 2-1/2 ZP	72	3	265310	Y CONNECTOR - 1/8 DIA-PL
10	1	9208	SCREW - HHCS 3/8-16 X 2-3/4 ZP	73	2	265404	PLASTIC RIVET
11	2	9209	SCREW - HHCS 3/8-16 X 3 ZP	74	4	505068	BUSHING - 4 PIECE
12	10	9226	NUT - HELN 5/16-18 ZP	75	1	555059	KNOB - T-BLACK
13	4	9227	NUT - HRLN 3/8-16 ZP	76	1	600881X	DISPLAY BOX - 5 WIN
14	16	9228	NUT - HELN 3/8-16 ZP	77	1	605056	DISPLAY BOX - BACK
15	1	9231	NUT - HJN 3/4-10 ZP	78	1	605428	GROUND CLAMP - DISPLAY
16	4	9272	SCREW - CRPHTS-TF #6-32 X 1/2 SS	79	1	953101	TUBING - .375 OD X .062 W-PE BLK
17	5	9279	SCREW - SBHTS-TF 5/16-18 X 3/4 ZP	80	1	953108	TUBING - 1/4 URETHANE BLK
18	3	9285	SCREW - CRPHTS 10-24 X 3/4 ZP	81	1	955300	STRIP - PROTECTOR-4 INCH
19	6	9291	SCREW - CRPHTS 8 X 1/2 ZP	82	2	962004	CON - 2MM-2-S
20	14	9353	WASHER - ACFT-5/16 ZP	83	5	962005	CON - MOD - P-4P-4C
21	32	9355	WASHER - FW-ACFT-3/8 SS	84	1	962016	CON - MOD-COUPLER-6-6
22	1	9364	WASHER - ITLW 3/4 ZP	85	4	962017	CON-MOD-P-6P-6C
23	4	9366	WASHER - ITLW #6 ZP	86	1	966701	WIRE - CABLE-4-26 GA
24	4	9389	WASHER - ITLW 5/16 ZP	87	1	966702	WIRE - CABLE-6-26GA
25	5	105423	BUMPER - MOLDED GLIDE	88	1	990806	ASSY - PROCESSOR BOX
26	1	105443	DECAL - SERIAL NUMBER	89	3	990812	KEY - DATA-CS
27	2	110830	ASSY - TB VALVE-DIG	90	2	995000	COLLAR - GRIP
28	2	110847	ASSY - EC-2.5 X 7	91	2	995001	CAP - GRIP W HOLE
29	1	110897	ASSY - QD-MALE	92	2	995160	GRIP - MOLDED
30	1	115000	BUSHING - TANK	93	1	995300	DECAL - TB-PLUS
31	2	115005	CLEVIS - CYLINDER-2-1/2	94	1	995301	DECAL - TB-MINUS
32	4	115051	BEARING - FLANGE-.5 ID	95	1	995308	DECAL - SEAT-POWER
33	1	115054	PLUG - 2 IN SQ-KEISER	96	1	995324	DECAL - MADE IN THE USA
34	1	115323	FILTER - IN LINE	97	1	995418	BAG - 4 X 6 X 4MIL-ZIP LOCK
35	1	115333	O-RING - .943 X .737 X .103	98	1	995615	PLACARD - ENG-POWER-BLK
36	3	115372	DECAL - KEISER LOGO-1 1/4" RED	99	1	995616	PLACARD - ENG-KEY-RED
37	4	115404	PLUG - HOLE-1 DIA				
38	26	115423	TIE - 8 IN-PL BLK				
39	1	115429	PLASTIC TIE - 10" RED				
40	10	135050	BEARING - FLANGE-1" ID				
41	4	135056	CAP - 1.500 SQ-PL				
42	4	135422	RUBBER CRUTCH TIP #20 BLK				
43	2	145420	CAM - FOLLOWER				
44	1	151825	ELECTRONIC BRACKET				
45	1	170891	ASSY - MUFFLER-LONG				
46	1	172180	PLUNGER				
47	1	175500	SPRING - PLUNGER				
48	1	210850	BACK CUSHION				
49	2	230853	SEAT CUSHION				
50	4	230856	LEG CUSHION				
51	1	230864	HEAD REST ASSEMBLY				
52	1	230865	LUMBAR ASSY				
53	1	230900	BOT FRM				
54	1	230901	TOP ADJUST TUBE				
55	1	230902	WELDT - DISPLAY MT				
56	1	230903	BACK FRAME				
57	2	230905	LEG SUPPORT				
58	1	230906	L EX ARM				
59	1	230907	R EX ARM				
60	1	230909	L LEVER ARM				
61	1	230910	R LEVER ARM				
62	1	230911	EXT BOT FRM				
63	2	230917	CAM				

2331XP-SA

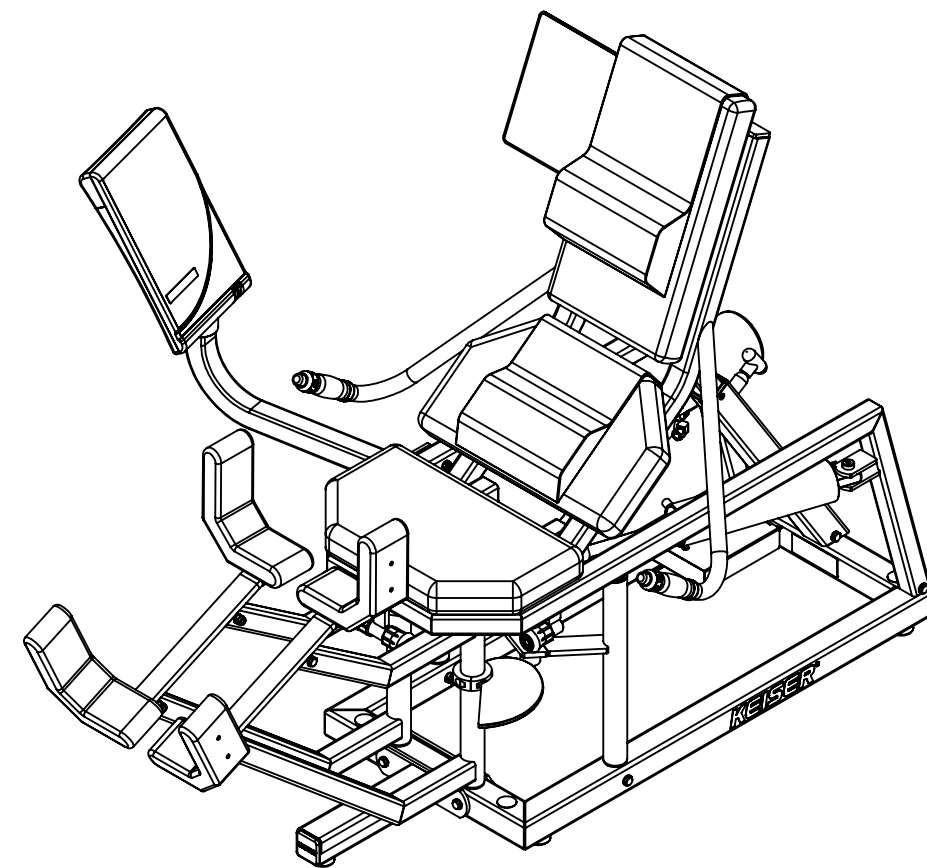

PRINTED ON: 9/10/2021 SW2006 V5.1

X:\drawings\REVISION\23_HIP_ABDUCTOR

KEISER®

2470 South Cherry Ave. Phone: (559) 256-8000
 Fresno, CA, USA 93706-5004 Fax: (559) 256-8100

THE INFORMATION DISCLOSED HEREIN WAS ORIGINATED BY AND IS THE PROPERTY OF KEISER CORP. AND ALL PATENT, PROPRIETARY, DESIGN, USE, SALE, MANUFACTURING, AND REPRODUCTION RIGHTS THERETO ARE RESERVED BY KEISER CORP.

DIMENSIONS ARE IN INCHES
 DIMENSIONS IN [] ARE MILLIMETERS
 BREAK SHARP EDGES .005-.015 [.10-.40]
 MACHINED SURFACE FINISH IS
 63 MICROINCHES [1.6 MICROMETERS]
 DO NOT SCALE DRAWING

DRAWN BY: JPR	DATE DRAWN: 7/19/21	CHECKED BY: LC	DATE CHECKED: 9/10/21
---------------	---------------------	----------------	-----------------------

MATERIAL: _____
 RAW MAT: _____

MASS (Kg): _____

REV	ECO	REVISION DESCRIPTION	BY	CKD	DATE
A	3928	REFERENCE ECO MEMO FOR DETAILS	JPR	LC	9/10/21

TITLE: **A300 HIP ABDUCTOR - PWR-SA**
 SHEET **2** OF **2** SCALE: **1:8** DRAWING SIZE: **A** PART#: **2331XP-SA**