

2936XP-SA

COMMONLY SERVICED COMPONENTS

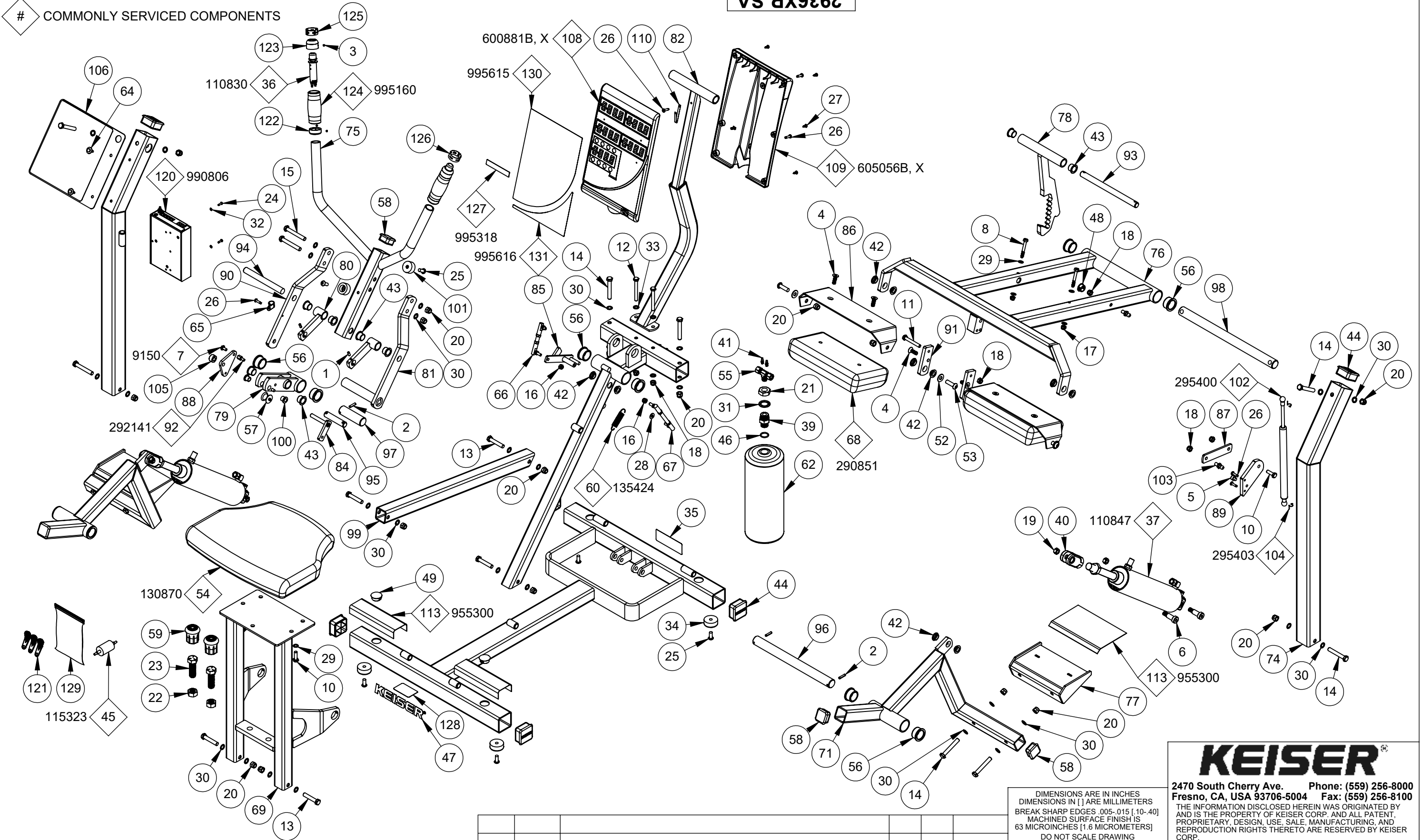

NOTE:
 (1) THIS DRAWING COVERS: 2936BP, 2936PP AND 293SP
 (2) FOLLOW ALL TOP LEVEL PROCEDURES

										DIMENSIONS ARE IN INCHES DIMENSIONS IN [] ARE MILLIMETERS BREAK SHARP EDGES .005-.015 [.10-.40] MACHINED SURFACE FINISH IS 63 MICROINCHES [1.6 MICROMETERS] DO NOT SCALE DRAWING		KEISER [®] 2470 South Cherry Ave. Phone: (559) 256-8000 Fresno, CA, USA 93706-5004 Fax: (559) 256-8100 THE INFORMATION DISCLOSED HEREIN WAS ORIGINATED BY AND IS THE PROPERTY OF KEISER CORP. AND ALL PATENT, PROPRIETARY, DESIGN, USE, SALE, MANUFACTURING, AND REPRODUCTION RIGHTS THERETO ARE RESERVED BY KEISER CORP.	
						DRAWN BY: BJU		DATE DRAWN: 6/18/21		CHECKED BY: LC		DATE CHECKED: 7/23/21	
						MATERIAL:						MASS (Kg):	
						RAW MAT:						TITLE: A300 SEATED CALF - PWR-SA	
A	3905	REFERENCE ECO MEMO FOR DETAILS				BJU	LC	7/26/21	SHEET 1 OF 2		SCALE: 1:10	DRAWING SIZE: B	PART#: 2936XP-SA
REV	ECO	REVISION DESCRIPTION				BY	CKD	DATE					

X:\drawings\REVISION29_SEATED_CALF PRINTED ON: 7/27/2021 SW2006 V5.1

ITEM NO.	QTY.	PART NO.	TITLE	ITEM NO.	QTY.	PART NO.	TITLE
1	2	9001	PIN SPRING - 3/16 X 1/2	64	2	265404	PLASTIC RIVET
2	3	9002	PIN SPRING - 3/16 X 7/8	65	1	275422	CLAMP - CABLE-0500
3	8	9014	SCREW - HSSS 8-32 X 1/8 SS	66	1	290806	ADJ STUD ASSY - SHORT
4	6	9075	SCREW - SFCHCS 5/16-18 X 1 ZP	67	1	290807	ADJ STUD ASSY - LONG
5	1	9104	SCREW - SHCS 5/16-18 X 1/4 ZP	68	2	290851	KNEE CUSHION
6	4	9127	SCREW - SHSS 1/2 X 1 ZP	69	1	290900	SEAT FRAME
7	1	9150	SCREW - HHCS 1/4-20 X 1/2 ZP	70	1	290902	BOT FRM
8	2	9152	SCREW - HHCS 1/4-20 X 2 ZP	71	1	290903	R EX ARM
9	1	9175	SCREW - HHCS 5/16-18 X 3/4 ZP	72	1	290904	L EX ARM
10	3	9176	SCREW - HHCS 5/16-18 X 1 ZP	73	1	290906	L SIDE FRM
11	1	9179	SCREW - HHCS 5/16-18 X 2-1/4 ZP	74	1	290907	R SIDE FRM
12	2	9181	SCREW - HHCS 5/16-18 X 2-3/4 ZP	75	1	290908	HANDLE BAR
13	5	9205	SCREW - HHCS 3/8-16 X 2 ZP	76	1	290909	KNEE PAD ARM
14	10	9207	SCREW - HHCS 3/8-16 X 2-1/2 ZP	77	2	290911	FOOT PEDAL
15	2	9208	SCREW - HHCS 3/8-16 X 2-3/4 ZP	78	1	290913	RACK
16	2	9220	NUT - HELN 1/4-28 ZP	79	1	290914	LEVER ARM
17	2	9225	NUT - HELN 1/4-20 ZP	80	2	290915	COMP LINK
18	6	9226	NUT - HELN 5/16-18 ZP	81	1	290916	L HANDLE BAR LEVER
19	4	9227	NUT - HRLN 3/8-16 ZP	82	1	290917	WELDT - DISPLAY MT
20	21	9228	NUT - HELN 3/8-16 ZP	83	1	290918	MID GUSSET
21	1	9231	NUT - HJN 3/4-10 ZP	84	1	290920	ROTATE LINK
22	2	9232	NUT - HN 5/8-18 NF ZP	85	1	290921	ENGAGEMENT LEVER
23	2	9251	SCREW - HHCS 5/8-18 X 2 ZP	86	2	291801	KNEE PAD BRKT
24	2	9272	SCREW - CRPHTS-TF #6-32 X 1/2 SS	87	1	291822	GAS SPRING BRKT BAR
25	6	9279	SCREW - SBHTS-TF 5/16-18 X 3/4 ZP	88	1	291843	ENGAGEMENT BRACKET
26	6	9285	SCREW - CRPHTS 10-24 X 3/4 ZP	89	1	291882	GAS SPRING BRKT MOUNT
27	6	9291	SCREW - CRPHTS 8 X 1/2 ZP	90	1	291887	HANDLE BAR LEVER
28	1	9349	WASHER - FW-SAE-1/4 ZP	91	2	291889	UPHOL MOUNTING BRKT
29	7	9353	WASHER - ACFT-5/16 ZP	92	1	292141	PIN - RACK GUIDE
30	34	9355	WASHER - FW-ACFT-3/8 SS	93	1	292180	RACK SHAFT
31	1	9364	WASHER - ITLW 3/4 ZP	94	1	292181	HANDLE BAR SHAFT - 5/8 DIA
32	2	9366	WASHER - ITLW #6 ZP	95	1	292182	LEVER ARM SHAFT - 5/8 DIA
33	4	9389	WASHER - ITLW 5/16 ZP	96	1	292240	EX ARM SHAFT
34	4	105423	BUMPER - MOLDED GLIDE	97	1	292241	LEVER ARM SHAFT
35	1	105443	DECAL - SERIAL NUMBER	98	1	292243	KNEE PAD ARM SHELF
36	2	110830	ASSY - TB VALVE-DIG	99	1	294174	SHORT GUSSET
37	2	110847	ASSY - EC-2.5 X 7	100	2	295001	BRONZE BEARING
38	1	110897	ASSY - QD-MALE	101	2	295052	PLASTIC STOP
39	1	115000	BUSHING - TANK	102	1	295400	GAS SPRING
40	2	115005	CLEVIS - CYLINDER-2-1/2	103	2	295401	BALL STUD - ZP
41	2	115019	BARBED CONN - 1/4 X 10-32	104	2	295403	RETAINING CLIP
42	14	115051	BEARING - FLANGE-.5 ID	105	1	295406	SHAFT COLLAR - 3/8
43	8	115052	BEARING - FLANGE-.625 ID	106	1	295447	PLACARD - A300 SEATED CALF
44	6	115054	PLUG - 2 IN SQ-KEISER	107	1	545055	ANCHOR - CABLE PL
45	1	115323	FILTER - IN LINE	108	1	600881	DISPLAY BOX 5 - WIN
46	1	115333	O-RING - .943 X .737 X .103	109	1	605056	DISPLAY BOX - BACK
47	1	115372	DECAL - KEISER LOGO-1 1/4" RED	110	1	605428	GROUND CLAMP - DISPLAY
48	1	115403	PLUG - HOLE-3/4 DIA	111	1	953101	TUBING - .375 OD X .062 W-PE BLK
49	4	115404	PLUG - HOLE-1 DIA	112	1	953108	TUBING - 1/4 URETHANE BLK
50	7	115423	TIE - 8 IN-PL BLK	113	1	955300	STRIP - PROTECTOR-4 INCH
51	1	115429	PLASTIC TIE - 10" RED	114	2	962004	CON - 2MM-2-S
52	4	115450	WASHER - FW .88 X .39 X .07 NP	115	6	962005	CON - MOD - P-4P-4C
53	4	115451	SCREW - SBHCS 3/8-16 X 1-1/4 NP	116	1	962016	CON - MOD-COUPLER-6-6
54	1	130870	CUSHION - SEAT-CURVED	117	4	962017	CON-MOD-P-6P-6C
55	1	135040	3/8 TAPPED TEE	118	1	966701	WIRE - CABLE-4-26 GA
56	10	135050	BEARING - FLANGE-1" ID				
57	2	135055	STEM BUMPER				
58	5	135056	CAP - 1.500 SQ-PL				
59	2	135422	RUBBER CRUTCH TIP #20 BLK				
60	1	135424	SPRING - PEDAL				
61	1	170891	ASSY - MUFFLER-LONG				
62	1	255318	TANK - 140 CU IN				
63	3	265310	Y CONNECTOR - 1/8 DIA-PL				

2936XP-SA

ITEM NO.	QTY.	PART NO.	TITLE
119	1	966702	WIRE - CABLE-6-26GA
120	1	990806	ASSY - PROCESSOR BOX
121	3	990812	KEY - DATA-CS
122	2	995000	COLLAR - GRIP
123	2	995001	CAP - GRIP W HOLE
124	2	995160	GRIP - MOLDED
125	1	995300	DECAL - TB-PLUS
126	1	995301	DECAL - TB-MINUS
127	1	995318	DECAL - NO ADJ-POWER
128	1	995324	DECAL - MADE IN THE USA
129	1	995418	BAG - 4 X 6 X 4MIL-ZIP LOCK
130	1	995615	PLACARD - ENG-POWER-BLK
131	1	995616	PLACARD - ENG-KEY-RED

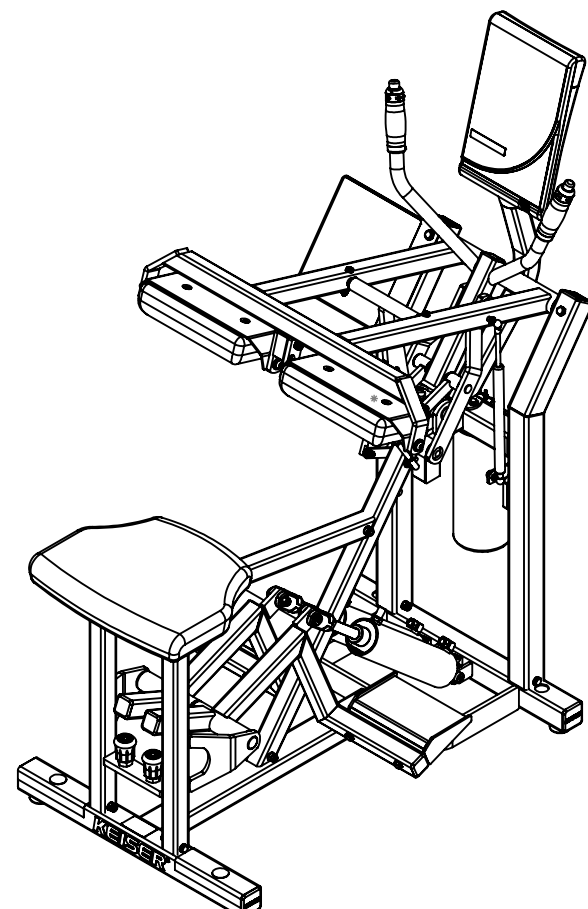

KEISER[®]
2470 South Cherry Ave. Phone: (559) 256-8000
Fresno, CA, USA 93706-5004 Fax: (559) 256-8100
 THE INFORMATION DISCLOSED HEREIN WAS ORIGINATED BY AND IS THE PROPERTY OF KEISER CORP. AND ALL PATENT, PROPRIETARY, DESIGN, USE, SALE, MANUFACTURING, AND REPRODUCTION RIGHTS THERETO ARE RESERVED BY KEISER CORP.

DIMENSIONS ARE IN INCHES
 DIMENSIONS IN [] ARE MILLIMETERS
 BREAK SHARP EDGES .005-.015 [.10-.40]
 MACHINED SURFACE FINISH IS
 63 MICROINCHES [1.6 MICROMETERS]
 DO NOT SCALE DRAWING

DRAWN BY: BJU	DATE DRAWN: 6/18/21	CHECKED BY: LC	DATE CHECKED: 7/23/21
MATERIAL:		RAW MAT:	
A 3905 REFERENCE ECO MEMO FOR DETAILS		BJU	LC
REV	ECO	REVISION DESCRIPTION	DATE
TITLE: A300 SEATED CALF - PWR-SA		SHEET 2 OF 2	
SCALE: 1:14		DRAWING SIZE: B	PART#: 2936XP-SA

PRINTED ON: 7/27/2021 SW2006 V5.1

X:\drawings\REVISION\29_SEATED_CALF